



ETSI EN 301 489-1 V2.2.3 (2019-11) ETSI EN 301 489-17 V3.2.4 (2020-09) EMC TEST REPORT

Client Information:

Applicant: Shenzhen pecron technology Co., LTD

Applicant add.: A503, No.2 Tian An Cyber Park, Longgang District, Shenzhen, China

Brand Name:



Product Information:

Product Name: Portable Power Station

Model No.: E300 LFP

Derivative model No.: N/A

Test Date: Dec. 08 to Dec.13, 2023

Issue Date: Dec.13, 2023

Test Result: PASS

Shenzhen iTC Product Testing Co., Ltd.

Issued by: Add. : Room 204, No.10, Phase 1, Xinhe Xinxing Third Industrial Area, Fuhai Road, Fuyong Street, Bao'an District, Shenzhen, Guangdong, China

This device has been tested and found to comply with the stated standard(s), which is (are) required by the council directive of 2014/53/EU and indicated in the test report and are applicable only to the tested sample identified in the report.

Note: This report shall not be reproduced except in full, without the written approval of Shenzhen iTC Product Testing Co., Ltd., this document may be altered or revised by Shenzhen iTC Product Testing Co., Ltd., personal only, and shall be noted in the revision of the document. This test report must not be used by the client to claim product endorsement.

Tested by

Max Zhuang

Max Zhuang

Reviewed by

Apple Huang

Apple Huang

Approved by

John Liu

John Liu



This test report may be reproduced in full only
Test result presented in this test report is applicable to the tested sample only



Report Revision History			
Report No.	Report Version	Description	Issue Date
23ITC1208105E	NONE	Original	Dec.13, 2023

Customer information	
Applicant Name	Shenzhen pecron technology Co., LTD
Applicant Address	A503, No.2 Tian An Cyber Park, Longgang District, Shenzhen, China
Manufacturer Name	Huizhou pecron technology Co.,LTD
Manufacturer Address	Gaowu section,Dongfeng Village ,Xinwei Town,Huiyang District,Huizhou City, China

Test site information	
Lab performing tests:	Shenzhen iTC Product Testing Co., Ltd.
Lab Address:	Room 204, No.10, Phase 1, Xinhe Xinxing Third Industrial Area, FuhaiRoad, Fuyong Street, Bao'an District, Shenzhen, Guangdong, China
Telephone:	(86)-0755-33138690
Fax:	(86)-0755-23071003

Measurement Uncertainty		
The reported uncertainty of measurement $y \pm U$, where expended uncertainty U is based on a standard uncertainty multiplied by a coverage factor of $k=2$, providing a level of confidence of approximately 95 %.		
A. Conducted Measurement :		
Method	Measurement Frequency Range	U · (dB)
ANSI	150KHz ~ 30MHz	3.2
B. Radiated Measurement :		
Method	Measurement Frequency Range	U · (dB)
ANSI	30MHz ~ 1000MHz	4.7
ANSI	1GHz ~6GHz	5.0

TABLE OF CONTENT

	Page
1 . TEST SUMMARY	5
2 . GENERAL INFORMATION	6
2.1 DESCRIPTION OF TEST MODES	7
2.2 DESCRIPTION OF TEST SETUP	8
2.3 DESCRIPTION TEST PERIPHERAL AND EUT PERIPHERAL	8
2.4 MEASUREMENT INSTRUMENTS LIST	9
3 . EMC EMISSION TEST	11
3.1 CONDUCTED EMISSION MEASUREMENT	11
3.1.1 POWER LINE CONDUCTED EMISSION	11
3.1.2 TEST PROCEDURE	12
3.1.3 TEST SETUP	12
3.1.4 EUT OPERATING CONDITIONS	12
3.2 RADIATED EMISSION MEASUREMENT	13
3.2.1 LIMITS OF RADIATED EMISSION MEASUREMENT	13
3.2.2 LIMITS OF RADIATED EMISSION MEASUREMENT	13
3.2.3 TEST PROCEDURE	13
3.2.4 TEST SETUP	14
3.2.5 EUT OPERATING CONDITIONS	14
3.2.6 TEST RESULTS (30-1000MHz)	15
3.2.7 TEST RESULTS(1000-6000)	17
3.3 HARMONICS CURRENT	19
3.3.1 LIMITS OF HARMONICS CURRENT	19
3.3.2 TEST PROCEDURE	19
3.3.3 TEST SETUP	20
3.3.4 TEST RESULTS	20
3.3.6 LIMITS OF VOLTAGE FLUCTUATION AND FLICKERS	21
3.3.7 TEST PROCEDURE	21
3.3.8 EUT OPERATING CONDITIONS	21
3.3.9 TEST SETUP	21
3.3.10 TEST RESULTS	21
4 . EMC IMMUNITY TEST	22
4.1 GENERAL PERFORMANCE CRITERIA	22
4.1.1 PERFORMANCE CRITERIA	22
4.2 ESD TESTING	23
4.2.1 TEST SPECIFICATION	23
4.2.2 TEST PROCEDURE	23
4.2.3 TEST SETUP	24
4.2.4 TEST RESULTS	25
4.3 RS TESTING	26

4.3.1 TEST SPECIFICATION	26
4.3.2 TEST PROCEDURE	26
4.3.3 TEST SETUP	27
4.3.4 TEST RESULTS	28
4.4 EFT/BURST TESTING	29
4.4.1 TEST SPECIFICATION	29
4.4.2 TEST PROCEDURE	29
4.4.3 TEST SETUP	30
4.4.4 TEST RESULTS	30
4.5 SURGE TESTING	31
4.5.1 TEST SPECIFICATION	31
4.5.2 TEST PROCEDURE	31
4.5.3 TEST SETUP	32
4.5.4 TEST RESULTS	32
4.6 INJECTION CURRENT TESTING	33
4.6.1 TEST SPECIFICATION	33
4.6.2 TEST PROCEDURE	33
4.6.3 TEST SETUP	34
4.6.4 TEST RESULTS	34
4.7 VOLTAGE INTERRUPTION/DIPS TESTING	35
4.7.1 TEST SPECIFICATION	35
4.7.2 TEST PROCEDURE	35
4.7.3 TEST SETUP	35
4.7.4 TEST RESULTS	35
5 . PHOTOS OF EUT	36

1. TEST SUMMARY

Test Procedures According To The Technical Standards:

ETSI EN 301 489-1 V2.2.3 (2019-11)

ETSI EN 301 489-17 V3.2.4 (2020-09)

EMC Emission				
Standard	Test Item	Product Class	Pass / Fail	Remark
EN 55032:2015+A11:2020	Conducted Emission	Class B	N/A	
	Radiated Emission	Class B	PASS	
EN IEC 61000-3-2:2019+A1:2021	Harmonic Current Emission	Class A or D	N/A	NOTE (2)
EN 61000-3-3:2013+A1:2019	Voltage Fluctuations & Flicker	Meets the requirements	N/A	NOTE (3)
EMC Immunity				
Section	Test Item	Product Class	Pass / Fail	Remark
EN 55035:2017+A11:2020				
EN 61000-4-2:2009	Electrostatic Discharge	Criteria TT&TR	PASS	
EN IEC 61000-4-3:2020	RF electromagnetic field	Criteria CT&CR	PASS	
EN 61000-4-4:2012	Fast transients	Criteria TT&TR	N/A	NOTE (3)
EN 61000-4-5:2014/A1:2017	Surges	Criteria TT&TR	N/A	NOTE (3)
EN 61000-4-6:2014+AC:2015	Injected Current	Criteria CT&CR	N/A	NOTE (3)
EN IEC 61000-4-11:2020	Volt. Interruptions Volt. Dips	Criteria TT&TR	N/A	NOTE (3)

NOTE:

(1)“ N/A” denotes test is not applicable in this Test Report.

(2) The power consumption of EUT is less than 75W and no Limits apply.

(3) The EUT employ battery power for operation and which do not operate from the AC power lines or contain provisions for operation while connected to the AC power lines. Measurements to demonstrate compliance with the conducted limits are not required for devices.

2. GENERAL INFORMATION

2.1 Description of Device (EUT)

Description of EUT	:	Portable Power Station
Main Model	:	E300 LFP
Serial Model	:	N/A
Model Difference	:	N/A
Trademark	:	
	:	Battery Capacity: 288Wh(19.2V 15Ah)
	:	AC Output(*2): 100V-120V~ 50/60Hz 600W Max
	:	USB-C(*1)Output: 5V $\overline{\text{---}}$ 3A,9V $\overline{\text{---}}$ 2A,12V $\overline{\text{---}}$ 1.5A, 20V $\overline{\text{---}}$ 5A 100W Max
	:	USB-A QC3.0(*2)Output: 5V $\overline{\text{---}}$ 3A,9V $\overline{\text{---}}$ 2A,12V $\overline{\text{---}}$ 1.5A,18W Max
Power supply	:	DC12V Output(*2):13.6V $\overline{\text{---}}$ 10A Max
	:	DC24V Output(*1):24V $\overline{\text{---}}$ 5A Max
	:	Wireless Output: 5-12V $\overline{\text{---}}$ 15W Max
	:	USB-C Charging: 20V $\overline{\text{---}}$ 5A Max 100W Max
	:	DC Chagring: 12-18V,100W Max
	:	AC Chagring: 100-120V,300W Max
Normal Test Voltage	:	DC19.2V
Adapter	:	N/A
Battery	:	288Wh(19.2V 15Ah)
Intend use environment	:	Residential, commercial and light industrial environment

For a more detailed features description, please refer to the manufacturer's specifications or the User's Manual.

2.1 DESCRIPTION OF TEST MODES

To investigate the maximum EMI emission characteristics generates from EUT, the test system was pre-scanning tested base on the consideration of following EUT operation mode or test configuration mode which possible have effect on EMI emission level. Each of these EUT operation mode(s) or test configuration mode(s) mentioned above was evaluated respectively.

For all Test Mode	Description
Mode 1	BT Mode
Mode 2	Link Mode
For Conducted Test	
Final Test Mode	Description
Mode 1	/
For Radiated Test	
Final Test Mode	Description
Mode 1	BT Mode
For EMS Test	
Mode 1	BT Mode
Mode 2	Link Mode
Note: The test modes were carried out for all operation modes(include link and idle).	

2.2 DESCRIPTION OF TEST SETUP

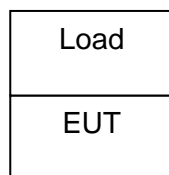

2.3 DESCRIPTION TEST PERIPHERAL AND EUT PERIPHERAL

The EUT has been tested as an independent unit together with other necessary accessories or support units. The following support units or accessories were used to form a representative test configuration during the tests.

Item	Equipment	Mfr/Brand	Model/Type No.	Series No.	Note
E-1	Portable Power Station		E300 LFP	N/A	N/A
E-2	Load	YBZ	YBZ1.1	Load	

Item	Shielded Type	Ferrite Core	Length	Note

Note:

- (1) The support equipment was authorized by Declaration of Confirmation.
- (2) For detachable type I/O cable should be specified the length in cm in 『Length』 column.



2.4 MEASUREMENT INSTRUMENTS LIST

CONDUCTED EMISSION

Item	Kind of Equipment	Manufacturer	Type No.	Serial No.	Last Cal.	Next Cal.
1	LISN	R&S	ENV216	101313	Jul. 06, 2023	Jul. 05, 2024
2	LISN	EMCO	3816/2	00042990	Jul. 06, 2023	Jul. 05, 2024
3	50Ω Switch	ANRITSU CORP	MP59B	6200983704	Jul. 06, 2023	Jul. 05, 2024
4	Test Cable	N/A	C01	N/A	Jul. 06, 2023	Jul. 05, 2024
5	Test Cable	N/A	C02	N/A	Jul. 06, 2023	Jul. 05, 2024
6	Test Cable	N/A	C03	N/A	Jul. 06, 2023	Jul. 05, 2024
7	EMI Test Receiver	R&S	ESCI	101160	Jul. 06, 2023	Jul. 05, 2024

RADIATED TEST SITE

Item	Kind of Equipment	Manufacturer	Type No.	Serial No.	Last Cal.	Next Cal.
1	Bilog Antenna	TESEQ	CBL6111D	31216	Jul. 06, 2023	Jul. 05, 2024
2	Test Cable	N/A	R-01	N/A	Jul. 06, 2023	Jul. 05, 2024
3	Test Cable	N/A	R-02	N/A	Jul. 06, 2023	Jul. 05, 2024
4	EMI Test Receiver	R&S	ESCI-7	101318	Jul. 06, 2023	Jul. 05, 2024
5	Antenna Mast	EM	SC100_1	N/A	N/A	N/A
6	Turn Table	EM	SC100	060531	N/A	N/A
7	50Ω Switch	Anritsu Corp	MP59B	6200983705	Jul. 06, 2023	Jul. 05, 2024
8	Spectrum Analyzer	Aglient	E4407B	MY45108040	Jul. 06, 2023	Jul. 05, 2024
9	Horn Antenna	EM	EM-AH-10180	2011071402	Jul. 06, 2023	Jul. 05, 2024
10	Amplifier	EM	EM-30180	060538	Jul. 06, 2023	Jul. 05, 2024

HARMONICS AND FILCK

Item	Kind of Equipment	Manufacturer	Type No.	Serial No.	Last Cal.	Next Cal.
1	Harmonic & Flicker	EM TEST	DPA500	0303-04	Jul. 06, 2023	Jul. 05, 2024
2	AC Power Source	EM TEST	ACS500	0203-01	Jul. 06, 2023	Jul. 05, 2024

ESD

Item	Kind of Equipment	Manufacturer	Type No.	Serial No.	Last Cal.	Next Cal.
1	ESD TEST GENERATOR	EVERFINE	EMS61000-2A-V200	11040001T	Jul. 06, 2023	Jul. 05, 2024

RS

Item	Kind of Equipment	Manufacturer	Type No.	Serial No.	Last Cal.	Next Cal.
1	Signal Generator	R&S	SMT 06	832080/007	Jul. 06, 2023	Jul. 05, 2024
2	Log-Bicon Antenna	Schwarzbeck	VULB9161	4022	Jul. 06, 2023	Jul. 05, 2024
3	Power Amplifier	AR	150W1000M1	320946	Jul. 06, 2023	Jul. 05, 2024
4	Microwave Horn Antenna	AR	AT4002A	321467	Jul. 06, 2023	Jul. 05, 2024
5	Power Amplifier	AR	25S1G4A	308598	Jul. 06, 2023	Jul. 05, 2024



SURGE, EFT/BURST, VOLTAGE INTERRUPTION/DIPS

Item	Kind of Equipment	Manufacturer	Type No.	Serial No.	Last Cal.	Next Cal.
1	Surge Generator	EMC-PARTNER	TRA2000	646	Jul. 06, 2023	Jul. 05, 2024
2	DIPS Generator	EMC-PARTNER	TRA2000	646	Jul. 06, 2023	Jul. 05, 2024
	EFT/B Generator	EMC-PARTNER	TRA2000	646	Jul. 06, 2023	Jul. 05, 2024

INJECTION CURRENT

Item	Kind of Equipment	Manufacturer	Type No.	Serial No.	Last Cal.	Next Cal.
1	Signal Generator	IFR	2023A	202301/368	Jul. 06, 2023	Jul. 05, 2024
2	Power Amplifier	AR	75A250AM1	0320709	Jul. 06, 2023	Jul. 05, 2024
3	CDN	FCC	FCC-801-M2	06043	Jul. 06, 2023	Jul. 05, 2024
4	EM Clamp	FCC	F-203I-23MM	504	Jul. 06, 2023	Jul. 05, 2024

3. EMC EMISSION TEST

3.1 CONDUCTED EMISSION MEASUREMENT

3.1.1 POWER LINE CONDUCTED EMISSION (Frequency Range 150KHz-30MHz)

FREQUENCY (MHz)	ClassA (dBuV)		Class B (dBuV)	
	Quasi-peak	Average	Quasi-peak	Average
0.15 -0.5	79.00	66.00	66-56 *	56 - 46 *
0.50 -5.0	73.00	60.00	56.00	46.00
5.0 -30.0	73.00	60.00	60.00	50.00

Note:

- (1) The tighter limit applies at the band edges.
- (2) The limit of " * " marked band means the limitation decreases linearly with the logarithm of the frequency in the range.

The following table is the setting of the receiver

Receiver Parameters	Setting
Attenuation	10 dB
Start Frequency	0.15 MHz
Stop Frequency	30 MHz
IF Bandwidth	9 kHz

3.1.2 TEST PROCEDURE

- a. The EUT was placed 0.4 meters from the horizontal ground plane with EUT being connected to the power mains through a line impedance stabilization network (LISN). All other support equipments powered from additional LISN(s). The LISN provide 50 Ohm/ 50uH of coupling impedance for the measuring instrument.
- b. Interconnecting cables that hang closer than 40 cm to the ground plane shall be folded back and forth in the center forming a bundle 30 to 40 cm long.
- c. I/O cables that are not connected to a peripheral shall be bundled in the center. The end of the cable may be terminated, if required, using the correct terminating impedance. The overall length shall not exceed 1 m.
- d. LISN at least 80 cm from nearest part of EUT chassis.
- e. For the actual test configuration, please refer to the related Item –EUT Test Photos.

3.1.3 TEST SETUP

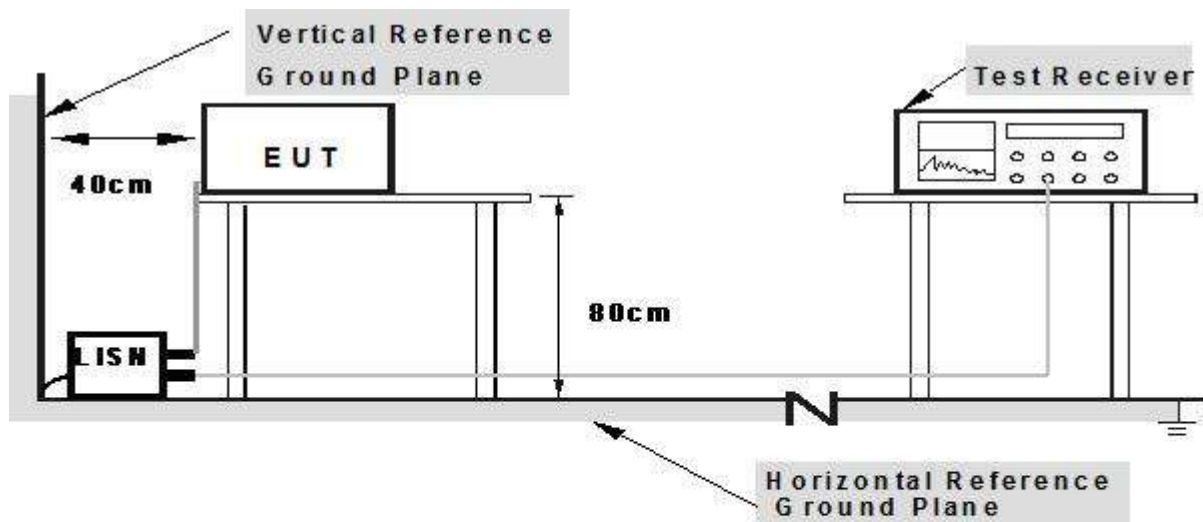

Note: 1. Support units were connected to second LISN.

2. Both of LISNs (AMN) are 80 cm from EUT and at least 80 from other units and other metal planes

3.1.4 EUT OPERATING CONDITIONS

The EUT tested system was configured as the statements of 2.2 Unless otherwise a special operating condition is specified in the follows during the testing.

3.1.5 TEST RESULTS

N/A.

3.2 RADIATED EMISSION MEASUREMENT

3.2.1 LIMITS OF RADIATED EMISSION MEASUREMENT (Below 1000MHz)

FREQUENCY (MHz)	Class A (at 10m)	Class B (at 10m)
	dBuV/m	dBuV/m
30 – 230	40	30
230 – 1000	47	37

3.2.2 LIMITS OF RADIATED EMISSION MEASUREMENT (Above 1000MHz)

FREQUENCY (MHz)	Class A (at 10m) dBuV/m		Class B (at 10m) dBuV/m	
	Peak	Avg	Peak	Avg
1000-3000	76	56	70	50
3000-6000	80	60	74	54

Notes:

- (1) The limit for radiated test was performed according to as following:
CISPR 22/ FCC PART 15B /ICES-003.
- (2) The tighter limit applies at the band edges.
- (3) Emission level (dBuV/m)=20log Emission level (uV/m).

3.2.3 TEST PROCEDURE

- a. The measuring distance of at 10 m shall be used for measurements at frequency up to 1GHz. For frequencies above 1GHz, any suitable measuring distance may be used.
- b. The EUT was placed on the top of a rotating table 0.8 meters above the ground at a 10 meter open area test site. The table was rotated 360 degrees to determine the position of the highest radiation.
- c. The height of the equipment or of the substitution antenna shall be 0.8 m; the height of the test antenna shall vary between 1 m to 4 m. Both horizontal and vertical polarizations of the antenna are set to make the measurement.
- d. The initial step in collecting conducted emission data is a spectrum analyzer peak detector mode pre-scanning the measurement frequency range. Significant peaks are then marked and then Quasi Peak detector mode re-measured.
- e. If the Peak Mode measured value compliance with and lower than Quasi Peak Mode Limit, the EUT shall be deemed to meet QP Limits and then no additional QP Mode measurement performed.
- f. For the actual test configuration, please refer to the related Item –EUT Test Photos.

3.2.4 TEST SETUP

(A) Radiated Emission Test Set-UP Frequency Below 1GHz

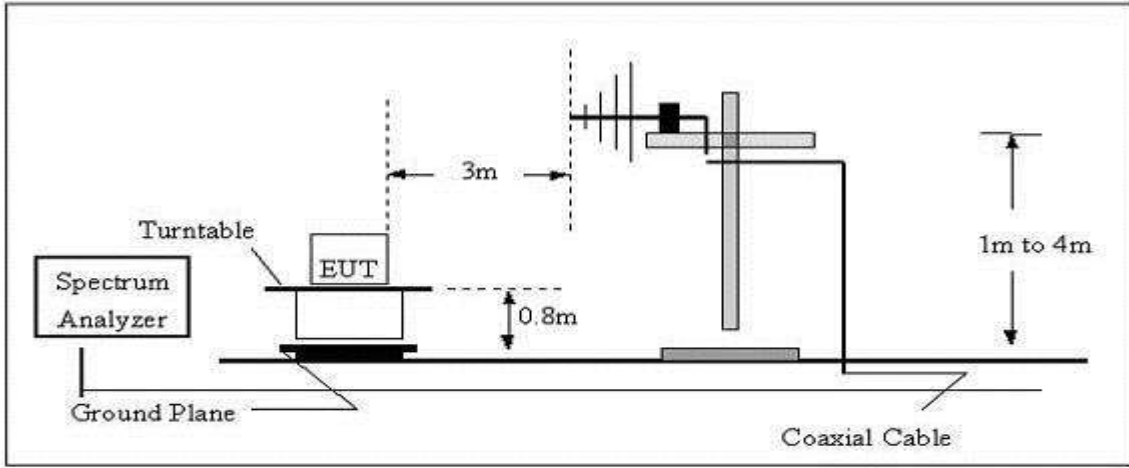

(B) Radiated Emission Test Set-UP Frequency Over 1GHz

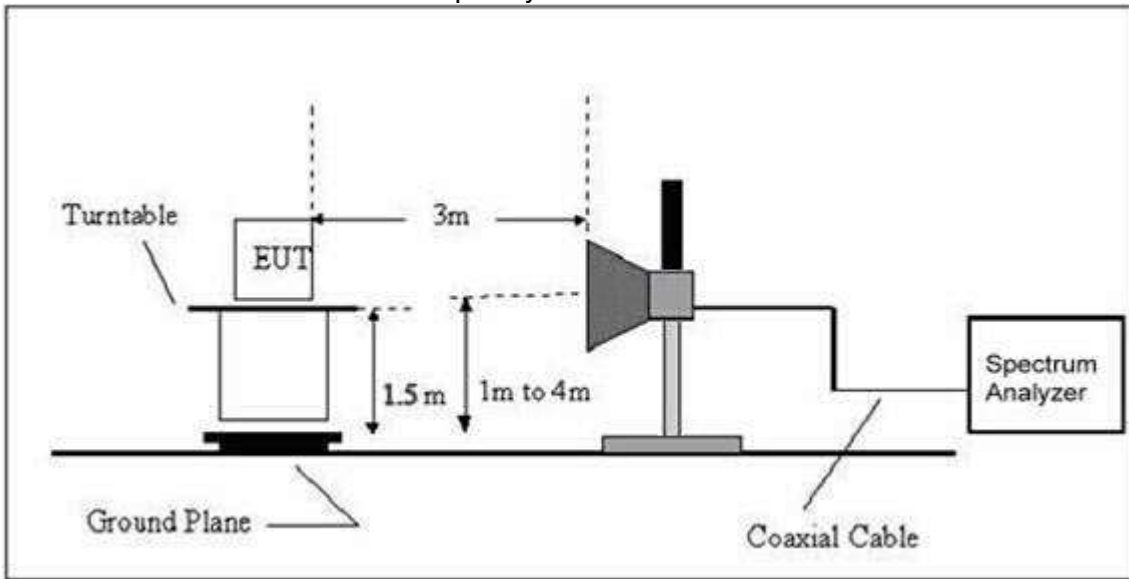

3.2.5 EUT OPERATING CONDITIONS

The EUT tested system was configured as the statements of 2.2 Unless otherwise a special operating condition is specified in the follows during the testing.

3.2.6 TEST RESULTS (30-1000MHz)

EUT :	Portable Power Station	Model Name :	E300 LFP
Temperature :	24 °C	Relative Humidity :	54%
Pressure :	1010 hPa	Polarization :	Horizontal
Test Voltage :	DC19.2V	Test Mode :	Mode 1

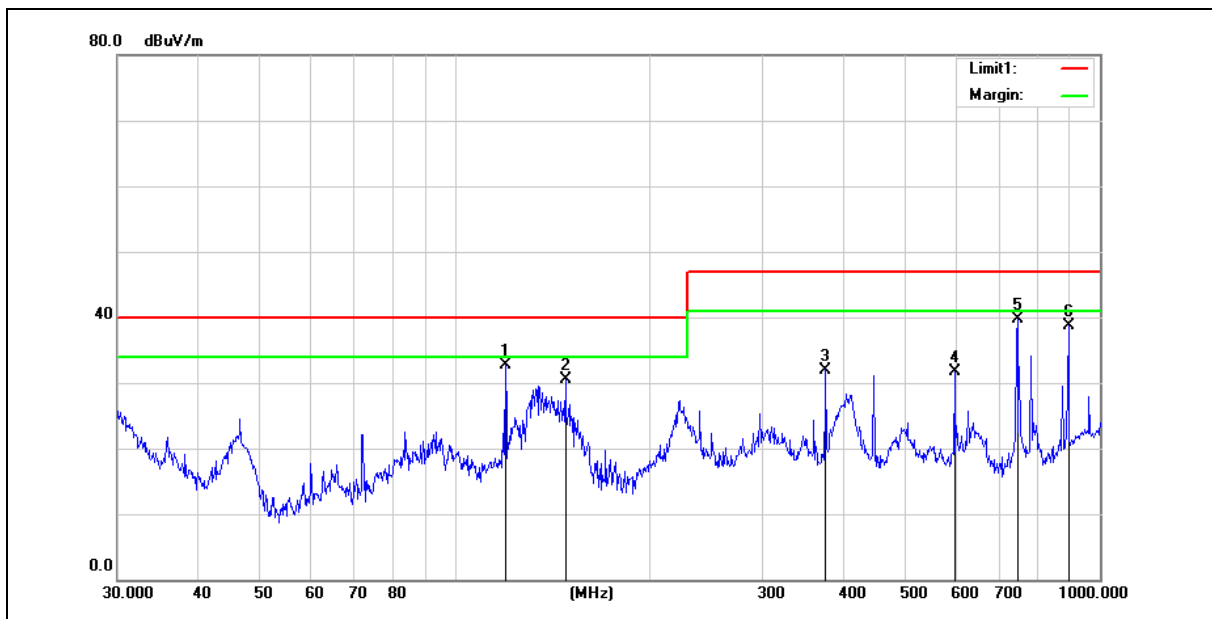

Remark:

1. All readings are Quasi-Peak and Average values.
2. Margin = Result (Result =Reading + Factor)–Limit

No.	Frequency (MHz)	Reading (dBuV)	Correction (dB/m)	Result (dBuV/m)	Limit (dBuV/m)	Margin (dB)	Remark
1	119.8555	51.73	-18.93	32.80	40.00	-7.20	QP
2	148.4410	47.55	-16.96	30.59	40.00	-9.41	QP
3	375.9384	48.51	-16.51	32.00	47.00	-15.00	QP
4	595.1327	44.31	-12.54	31.77	47.00	-15.23	QP
5	744.8660	50.47	-10.76	39.71	47.00	-7.29	QP
6	893.8567	47.45	-8.82	38.63	47.00	-8.37	QP

EUT :	Portable Power Station	Model Name :	E300 LFP
Temperature :	24 °C	Relative Humidity :	54%
Pressure :	1010 hPa	Polarization :	Vertical
Test Voltage :	DC19.2V	Test Mode :	Mode 1

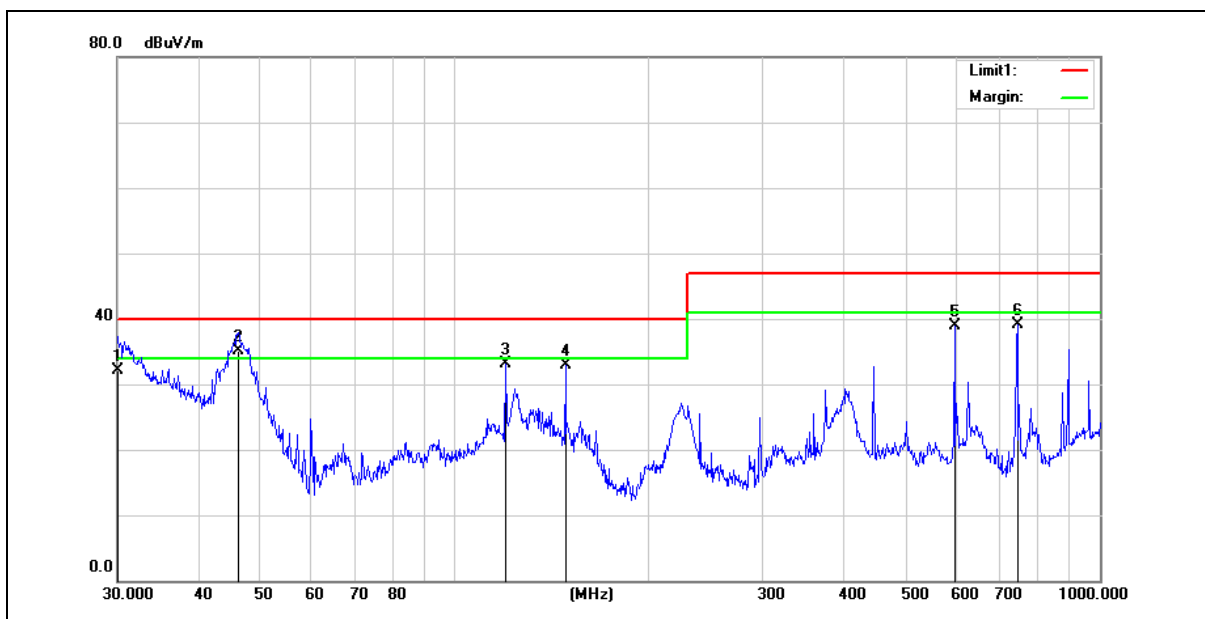

Remark:

1. All readings are Quasi-Peak and Average values.
2. Margin = Result (Result = Reading + Factor) – Limit

No.	Frequency (MHz)	Reading (dBuV)	Correction (dB/m)	Result (dBuV/m)	Limit (dBuV/m)	Margin (dB)	Remark
1	30.0590	42.76	-10.70	32.06	40.00	-7.94	QP
2	46.2773	55.29	-20.20	35.09	40.00	-4.91	QP
3	119.8555	52.08	-18.93	33.15	40.00	-6.85	QP
4	148.4410	49.78	-16.96	32.82	40.00	-7.18	QP
5	595.1327	51.47	-12.54	38.93	47.00	-8.07	QP
6	744.8660	49.85	-10.76	39.09	47.00	-7.91	QP

3.2.7 TEST RESULTS(1000-6000)

Temperature:	24 °C	Relative Humidity:	54 %
Pressure:	1010hPa	Test Mode:	Mode 1
Test Power:	DC19.2V		

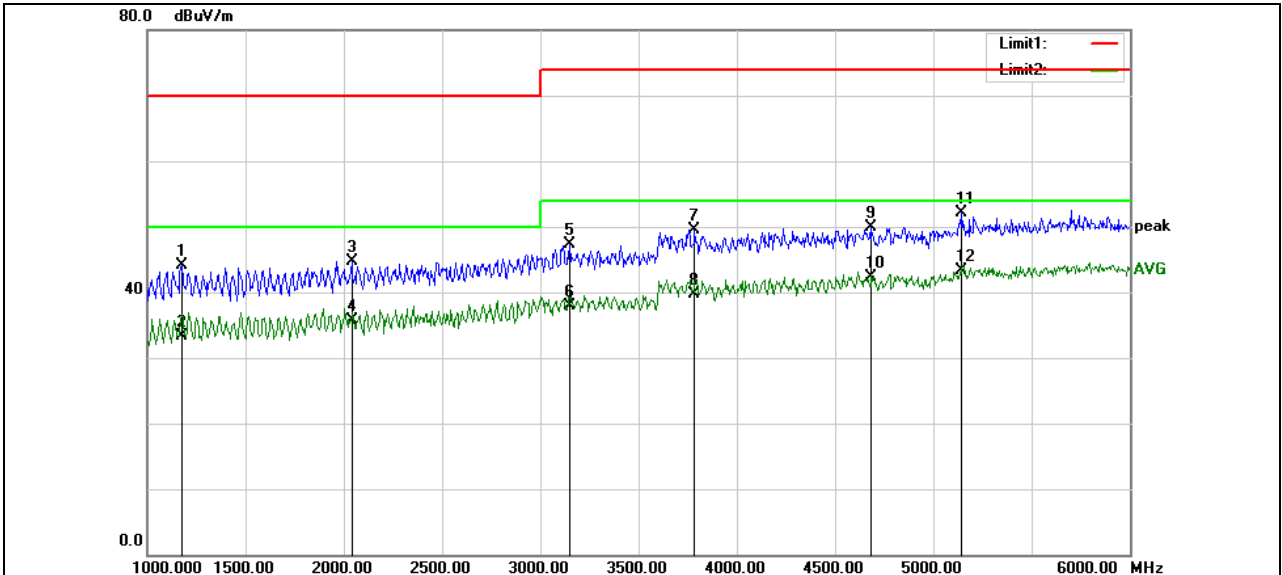

Remark:

1. Factor = Antenna Factor + Cable Loss – Pre-amplifier.

No.	Frequency (MHz)	Reading (dBuV)	Correction (dB/m)	Result (dBuV/m)	Limit (dBuV/m)	Margin (dB)	Remark
1	1175.000	47.23	-3.22	44.01	70.00	-25.99	peak
2	1175.000	36.51	-3.22	33.29	50.00	-16.71	AVG
3	2040.000	45.83	-1.12	44.71	70.00	-25.29	peak
4	2040.000	36.75	-1.12	35.63	50.00	-14.37	AVG
5	3150.000	45.05	2.16	47.21	74.00	-26.79	peak
6	3150.000	35.81	2.16	37.97	54.00	-16.03	AVG
7	3785.000	45.72	3.80	49.52	74.00	-24.48	peak
8	3785.000	35.83	3.80	39.63	54.00	-14.37	AVG
9	4680.000	44.83	4.99	49.82	74.00	-24.18	peak
10	4680.000	37.27	4.99	42.26	54.00	-11.74	AVG
11	5145.000	45.61	6.41	52.02	74.00	-21.98	peak
12	5145.000	36.92	6.41	43.33	54.00	-10.67	AVG

Temperature:	24 °C	Relative Humidity:	54 %
Pressure:	1010hPa	Test Mode:	Mode 1
Test Power:	DC19.2V		

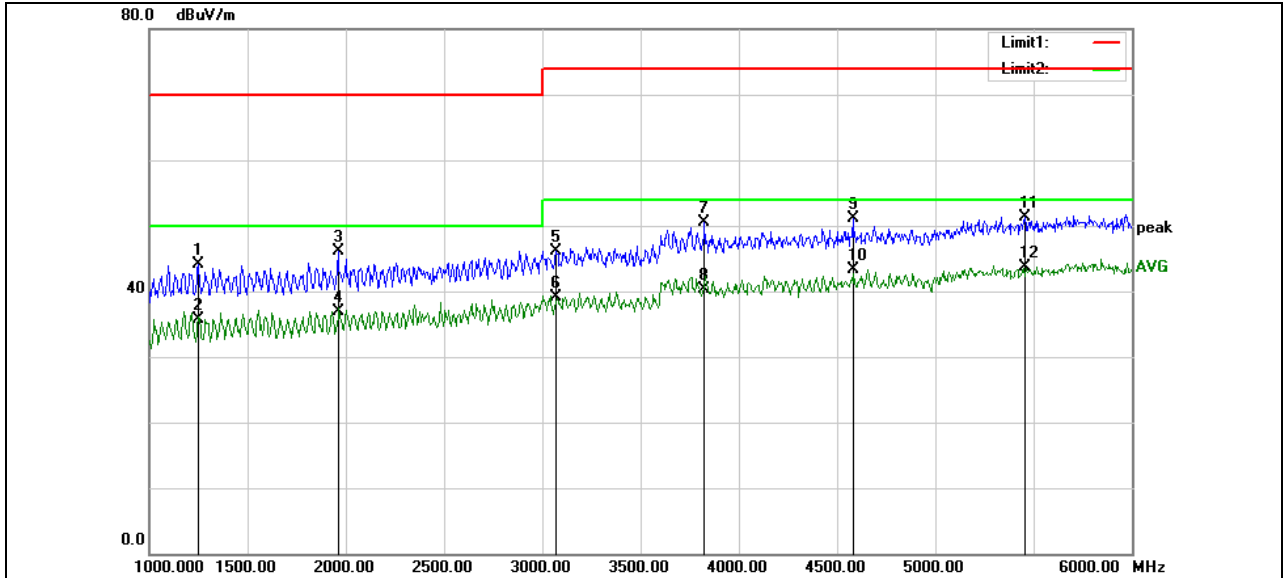

Remark:

1. Factor = Antenna Factor + Cable Loss – Pre-amplifier.

No.	Frequency (MHz)	Reading (dBuV)	Correction (dB/m)	Result (dBuV/m)	Limit (dBuV/m)	Margin (dB)	Remark
1	1250.000	47.16	-3.09	44.07	70.00	-25.93	peak
2	1250.000	38.76	-3.09	35.67	50.00	-14.33	AVG
3	1960.000	47.32	-1.23	46.09	70.00	-23.91	peak
4	1960.000	38.04	-1.23	36.81	50.00	-13.19	AVG
5	3070.000	43.94	2.17	46.11	74.00	-27.89	peak
6	3070.000	36.88	2.17	39.05	54.00	-14.95	AVG
7	3825.000	46.57	3.91	50.48	74.00	-23.52	peak
8	3825.000	36.30	3.91	40.21	54.00	-13.79	AVG
9	4580.000	46.44	4.63	51.07	74.00	-22.93	peak
10	4580.000	38.66	4.63	43.29	54.00	-10.71	AVG
11	5455.000	43.92	7.38	51.30	74.00	-22.70	peak
12	5455.000	36.31	7.38	43.69	54.00	-10.31	AVG

3.3 HARMONICS CURRENT

3.3.1 LIMITS OF HARMONICS CURRENT

IEC 555-2					
Table - I			Table - II		
Equipment Category	Harmonic Order n	Max. Permissible Harmonic Current (in Amperes)	Equipment Category	Harmonic Order n	Max. Permissible Harmonic Current (in Amperes)
Non Portable Tools or TV Receivers	Odd Harmonics		TV Receivers	Odd Harmonics	
	3	2.30		3	0.80
	5	1.14		5	0.60
	7	0.77		7	0.45
	9	0.40		9	0.30
	11	0.33		11	0.17
	13	0.21		13	0.12
	$15 \leq n \leq 39$	$0.15 \cdot 15/n$		$15 \leq n \leq 39$	$0.10 \cdot 15/n$
	Even Harmonics			Even Harmonics	
	2	1.08		2	0.30
4	0.43	4	0.15		
8	0.30				
$8 \leq n \leq 40$	$0.23 \cdot 8/n$	DC	0.05		

EN 61000-3-2/IEC 61000-3-2					
Equipment Category	Max. Permissible Harmonic Current (in Amperes)	Equipment Category	Harmonic Order n	Max. Permissible Harmonic Current (in A)	Max. Permissible Harmonic Current (mA/w)
Class A	Same as Limits Specified in 4-2.1, Table - I, but only odd harmonics required	Class D	3	2.30	3.4
			5	1.14	1.9
			7	0.77	1.0
			9	0.40	0.5
			11	0.33	0.35
			$13 \leq n \leq 39$	see Table I	$3.85/n$
only odd harmonics required					

3.3.2 TEST PROCEDURE

- The EUT was placed on the top of a wooden table 0.8 meters above the ground and operated to produce the maximum harmonic components under normal operating conditions.
- The classification of EUT is according to section 5 of EN 61000-3-2: 2000. The EUT is classified as follows:
 Class A: Balanced three-phase equipment, Household appliances excluding equipment as Class D, Tools excluding portable tools, Dimmers for incandescent lamps, audio equipment, equipment not specified in one of the three other classes.
 Class B: Portable tools. Portable tools.; Arc welding equipment which is not professional equipment.
 Class C: Lighting equipment.
 Class D: Equipment having a specified power less than or equal to 600 W of the following types: Personal computers and personal computer monitors and television receivers.
- The correspondent test program of test instrument to measure the current harmonics emanated from EUT is chosen. The measure time shall be not less than the time necessary for the EUT to be exercised.
- For the actual test configuration, please refer to the related item –EUT Test Photos.

3.3.3 TEST SETUP

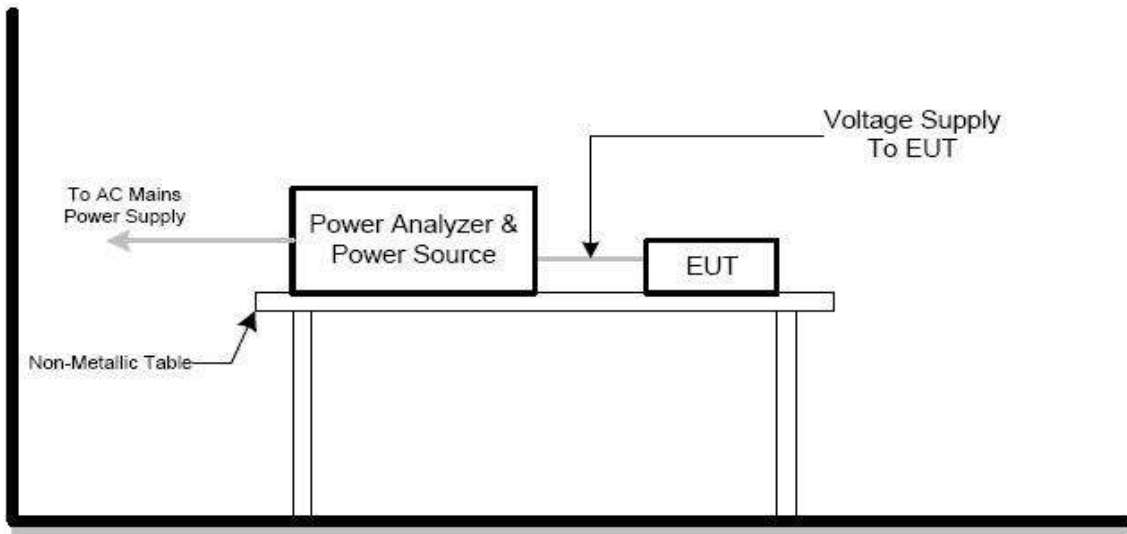

3.3.4 TEST RESULTS

EUT :	Portable Power Station	Model Name :	E300 LFP
Temperature :	25 °C	Relative Humidity :	45%
Pressure :	1010 hPa	Test Power :	DC19.2V
Test Mode	N/A		

Since the EUT (rated power is less than 75W) was belong to exception of clause 7 and Annex C, according to EN 61000-3-2 figure 1, it was deemed to conform to the requirements of this standard without further testing.

3.3.5 VOLTAGE FLUCTUATION AND FLICKERS

3.3.6 LIMITS OF VOLTAGE FLUCTUATION AND FLICKERS

Tests	Limits		Descriptions
	IEC555-3	IEC/EN 61000-3-3	
Pst	≤ 1.0, Tp= 10 min.	≤ 1.0, Tp= 10 min.	Short Term Flicker Indicator
Plt	N/A	≤ 0.65, Tp=2 hr.	Long Term Flicker Indicator
dc	≤ 3%	≤ 3.3%	Relative Steady-State V-Chang
dmax	≤ 4%	≤ 4%	Maximum Relative V-change
d (t)	N/A	≤ 3.3% for > 500 ms	Relative V-change characteristic

3.3.7 TEST PROCEDURE

a. Harmonic Current Test:

Test was performed according to the procedures specified in Clause 5.0 of IEC555-2 and/or Sub-clause 6.2 of IEC/EN 61000-3-2 depend on which standard adopted for compliance measurement.

b. Fluctuation and Flickers Test:

Tests was performed according to the Test Conditions/Assessment of Voltage Fluctuations specified in Clause 5.0/6.0 of IEC555-3 and/or Clause 6.0/4.0 of IEC/EN 61000-3-3 depend on which standard adopted for compliance measurement.

c. All types of harmonic current and/or voltage fluctuation in this report are assessed by direct measurement using flicker-meter.

d. For the actual test configuration, please refer to the related Item –EUT Test Photos.

3.3.8 EUT OPERATING CONDITIONS

The EUT tested system was configured as the statements of 2.2 Unless otherwise a special operating condition is specified in the follows during the testing.

3.3.9 TEST SETUP

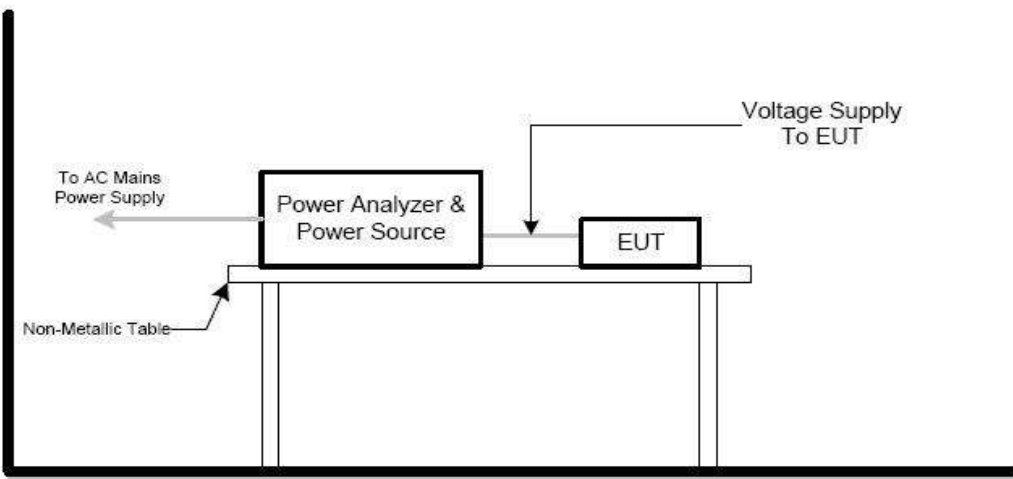

3.3.10 TEST RESULTS

N/A.

4. EMC IMMUNITY TEST

4.1 GENERAL PERFORMANCE CRITERIA

4.1.1 PERFORMANCE CRITERIA

According To **EN 301489 -17** standard, The General Performance Criteria As Following:

Criteria	During test	After test
A	Shall operate as intended. May show degradation of performance (see note 1). Shall be no loss of function. Shall be no unintentional transmissions.	Shall operate as intended. Shall be no degradation of performance (see note 2). Shall be no loss of function. Shall be no loss of stored data or user programmable functions.
B	May show loss of function (one or more). May show degradation of performance (see note 1). No unintentional transmissions.	Functions shall be self-recoverable. Shall operate as intended after recovering. Shall be no degradation of performance (see note 2). Shall be no loss of stored data or user programmable functions.
C	May be loss of function (one or more).	Functions shall be recoverable by the operator. Shall operate as intended after recovering. Shall be no degradation of performance (see note 2).

NOTE 1: Degradation of performance during the test is understood as a degradation to a level not below a minimum performance level specified by the manufacturer for the use of the apparatus as intended. In some cases the specified minimum performance level may be replaced by a permissible degradation of performance.

If the minimum performance level or the permissible performance degradation is not specified by the manufacturer then either of these may be derived from the product description and documentation (including leaflets and advertising) and what the user may reasonably expect from the apparatus if used as intended.

NOTE 2: No degradation of performance after the test is understood as no degradation below a minimum Performance level specified by the manufacturer for the use of the apparatus as intended. In some cases the specified minimum performance level may be replaced by a permissible degradation of performance. After the test no change of actual operating data or user retrievable data is allowed.

If the minimum performance level or the permissible performance degradation is not specified by the manufacturer then either of these may be derived from the product description and documentation (including leaflets and what the user may reasonably expect from the apparatus if used as intended.)

Performance criteria for CT and CR:

The performance criteria A shall apply.

Tests shall be repeated with the EUT in standby mode (if applicable) to ensure that unintentional transmission does not occur. Where the EUT is a transceiver, under no circumstances, shall the transmitter operate unintentionally during the test. In systems using acknowledgement signals, it is recognized that an ACK or NACK transmission may occur, and steps should be taken to ensure that any transmission resulting from the application of the test is correctly interpreted.

Performance criteria for TT and TR:

The performance criteria B shall apply, except for voltage dips of 100 ms and voltage interruptions of 5 000 ms duration, for which performance criteria C shall apply. Tests shall be repeated with the EUT in standby mode (if applicable) to ensure that unintentional transmission does not occur. Where the EUT is a transceiver, under no circumstances, shall the transmitter operate unintentionally during the test. In systems using acknowledgement signals, it is recognized that an ACK or NACK transmission may occur, and steps should be taken to ensure that any transmission resulting from the application of the test is correctly interpreted.

4.2 ESD TESTING

4.2.1 TEST SPECIFICATION

Basic Standard:	IEC/EN 61000-4-2
Discharge Impedance:	330 ohm / 150 pF
Required Performance	B
Discharge Voltage:	Air Discharge : 2kV/4kV/8kV (Direct) Contact Discharge : 2kV/4kV (Direct/Indirect)
Polarity:	Positive & Negative
Number of Discharge:	Air Discharge: min. 20 times at each test point Contact Discharge: min. 200 times in total
Discharge Mode:	AC Discharge
Discharge Period:	1 second minimum

4.2.2 TEST PROCEDURE

The test generator necessary to perform direct and indirect application of discharges to the EUT in the following manner:

- a. Contact discharge was applied to conductive surfaces and coupling planes of the EUT. During the test, it was performed with single discharges. For the single discharge time between successive single discharges was at least 1 second. The EUT shall be exposed to at least 200 discharges, 100 each at negative and positive polarity, at a minimum of four test points. One of the test points shall be subjected to at least 50 indirect discharges to the center of the front edge of the horizontal coupling plane. The remaining three test points shall each receive at least 50 direct contact discharges. If no direct contact test points are available, then at least 200 indirect discharges shall be applied in the indirect mode. Test shall be performed at a maximum repetition rate of one discharge per second.
 - Vertical Coupling Plane (VCP):
The coupling plane, of dimensions 0.5m x 0.5m, is placed parallel to, and positioned at a distance 0.1m from, the EUT, with the Discharge Electrode touching the coupling plane. The four faces of the EUT will be performed with electrostatic discharge.
 - Horizontal Coupling Plane (HCP):
The coupling plane is placed under to the EUT. The generator shall be positioned vertically at a distance of 0.1m from the EUT, with the Discharge Electrode touching the coupling plane. The four faces of the EUT will be performed with electrostatic discharge.
- b. Air discharges at insulation surfaces of the EUT. It was at least ten single discharges with positive and negative at the same selected point.
- c. For the actual test configuration, please refer to the related Item –EUT Test Photos.

4.2.3 TEST SETUP

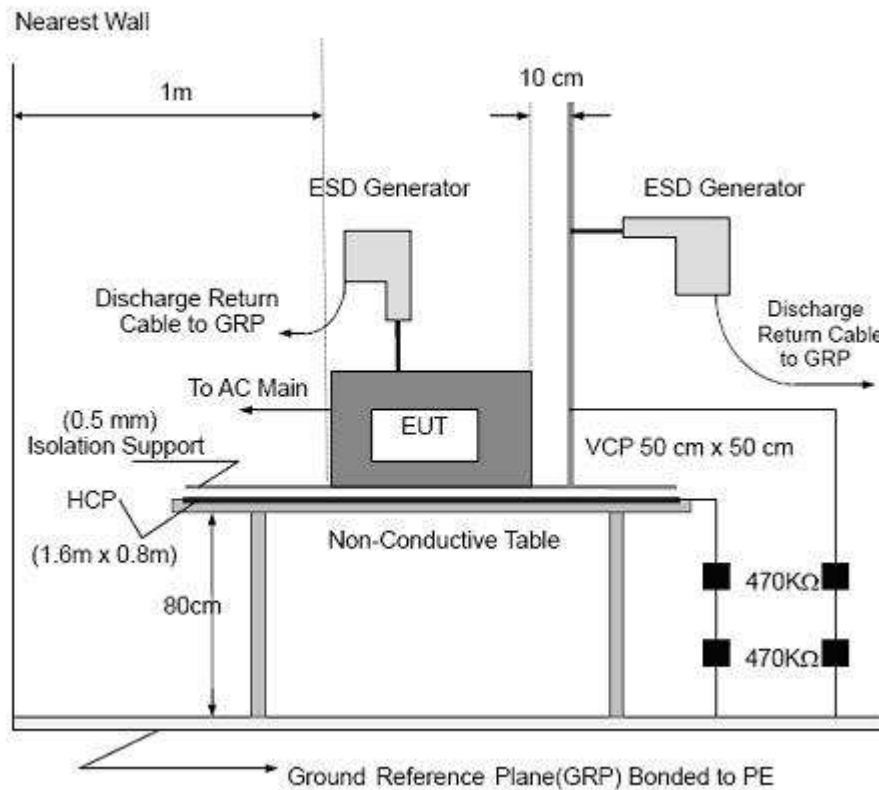

Note:

TABLE-TOP EQUIPMENT

The configuration consisted of a wooden table 0.8 meters high standing on the Ground Reference Plane. The GRP consisted of a sheet of aluminum at least 0.25mm thick, and 2.5 meters square connected to the protective grounding system. A Horizontal Coupling Plane (1.6m x 0.8m) was placed on the table and attached to the GRP by means of a cable with 940k total impedance. The equipment under test, was installed in a representative system as described in section 7 of IEC /EN 61000-4-2, and its cables were placed on the HCP and isolated by an insulating support of 0.5mm thickness. A distance of 1-meter minimum was provided between the EUT and the walls of the laboratory and any other metallic structure.

FLOOR-STANDING EQUIPMENT

The equipment under test was installed in a representative system as described in section 7 of IEC/EN 61000-4-2, and its cables were isolated from the Ground Reference Plane by an insulating support of 0.1-meter thickness. The GRP consisted of a sheet of aluminum that is at least 0.25mm thick, and 2.5meters square connected to the protective grounding system and extended at least 0.5 meters from the EUT on all sides.

4.2.4 TEST RESULTS

EUT :	Portable Power Station	Model Name :	E300 LFP
Temperature :	25 °C	Relative Humidity :	45%
Pressure :	1010 hPa	Test Power :	DC19.2V
Test Mode	Mode1/2		

Mode	Air Discharge								Contact Discharge								Observation	Criterion	Result	
	2		4		8		10		2		4		6		8					
	+	-	+	-	+	-	+	-	+	-	+	-	+	-	+	-				
HCP										A	A	A	A					TT,TR	B	PASS
VCP										A	A	A	A							PASS
port										A	A	A	A							PASS
enclosure	A	A	A	A	A	A														PASS
Button	A	A	A	A	A	A														PASS

Note:

- 1) P/N denotes the Positive/Negative polarity of the output voltage.
- 2) Test condition:
 Direct / Indirect (HCP/VCP) discharges: Minimum 50 times (Positive/Negative) at each point. Air discharges: Minimum 10 times (Positive/Negative) at each point.
- 3) N/A - denotes test is not applicable in this test report
- 4) There was not any unintentional transmission in standby mode

4.3 RS TESTING

4.3.1 TEST SPECIFICATION

Basic Standard:	IEC/EN 61000-4-3
Required Performance	A
Frequency Range:	80 MHz - 6000 MHz
Field Strength:	3 V/m
Modulation:	1kHz Sine Wave, 80%, AM Modulation
Frequency Step:	1 % of fundamental
Polarity of Antenna:	Horizontal and Vertical
Test Distance:	3 m
Antenna Height:	1.5 m
Dwell Time:	at least 3 seconds

4.3.2 TEST PROCEDURE

The EUT and support equipment, which are placed on a table that is 0.8 meter above ground and the testing was performed in a fully-anechoic chamber.

The testing distance from antenna to the EUT was 3 meters.

The other condition as following manner:

- a. The field strength level was 3V/m.
- b. The frequency range is swept from 80 MHz to 6000 MHz, & 1400MHz - 2700MHz with the signal 80%amplitude modulated with a 1kHz sine wave. The rate of sweep did not exceed 1.5x 10⁻³ decade/s. Where the frequency range is swept incrementally, the step size was 1% of fundamental.
- c. Sweep Frequency 900 MHz, with the Duty Cycle:1/8 and Modulation: Pulse 217 Hz(if applicable)
- d. The dwell time at each frequency shall be not less than the time necessary for the EUT to be able to respond.
- e. The test was performed with the EUT exposed to both vertically and horizontally polarized fields on each of the four sides.
- f. For the actual test configuration, please refer to the related Item –EUT Test Photos.

4.3.3 TEST SETUP

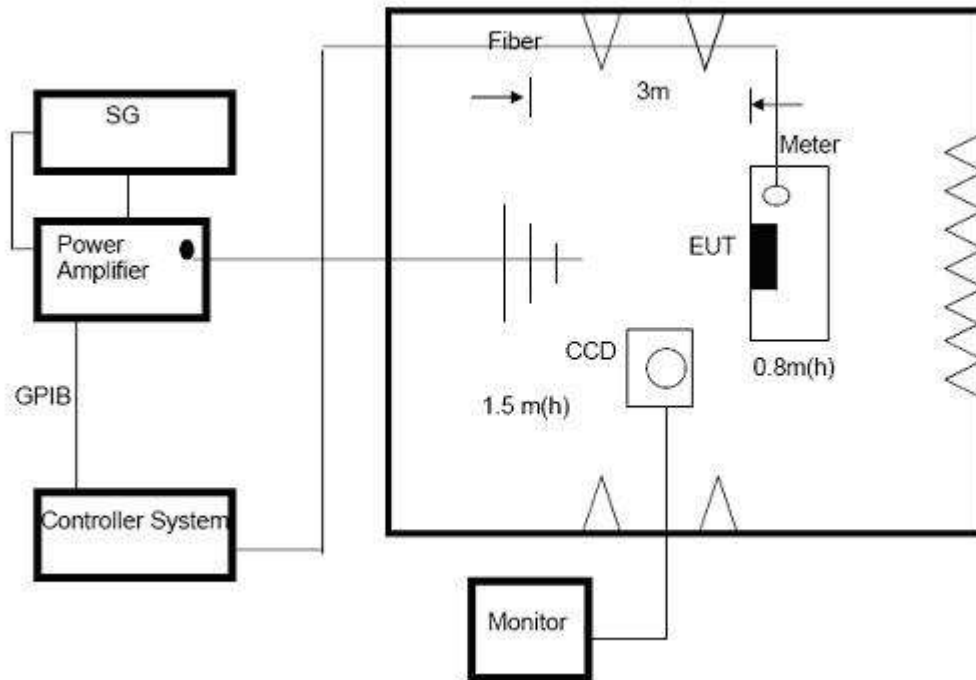

Note:

TABLE-TOP EQUIPMENT

The EUT installed in a representative system as described in section 7 of IEC/EN 61000-4-3 was placed on a non-conductive table 0.8 meters in height. The system under test was connected to the power and signal wire according to relevant installation instructions.

FLOOR-STANDING EQUIPMENT

The EUT installed in a representative system as described in section 7 of IEC/EN 61000-4-3 was placed on a non-conductive wood support 0.1 meters in height. The system under test was connected to the power and signal wire according to relevant installation instructions.

4.3.4 TEST RESULTS

EUT :	Portable Power Station	Model Name :	E300 LFP
Temperature :	25 °C	Relative Humidity :	45%
Pressure :	1010 hPa	Test Power :	DC19.2V
Test Mode	Mode1/2		

TEST RESULTS

Frequency Range (MHz)	RF Field Position	R.F. Field Strength	Azimuth	Observation	Perform. Criteria	Results	Judgment
80~6000	H / V	3 V/m (rms) AM Modulated 1000Hz, 80%	Front	CT,CR	A	A	PASS
			Rear				
			Left				
			Right				

Note: "A" stand for, during test, operate as intended no loss of function, no degradation of performance, no unintentional transmissions and after test, no degradation of performance, no loss of function, no loss of stored data or user programmable functions.

4.4 EFT/BURST TESTING

4.4.1 TEST SPECIFICATION

Basic Standard:	IEC/EN 61000-4-4
Required Performance	B
Test Voltage:	Power Line : 1 kV Signal/Control Line : 0.5 KV
Polarity:	Positive & Negative
Impulse Frequency:	5 kHz
Impulse Wave shape :	5/50 ns
Burst Duration:	15 ms
Burst Period:	300 ms
Test Duration:	Not less than 1 min.

4.4.2 TEST PROCEDURE

The EUT and support equipment, are placed on a table that is 0.8 meter above a metal ground plane measured 1m*1m min. and 0.65mm thick min.

The other condition as following manner:

- a. The length of power cord between the coupling device and the EUT should not exceed 1 meter.
- b. Both positive and negative polarity discharges were applied.
- c. The duration time of each test sequential was 1 minute
- d. For the actual test configuration, please refer to the related Item –EUT Test Photos.

4.4.3 TEST SETUP

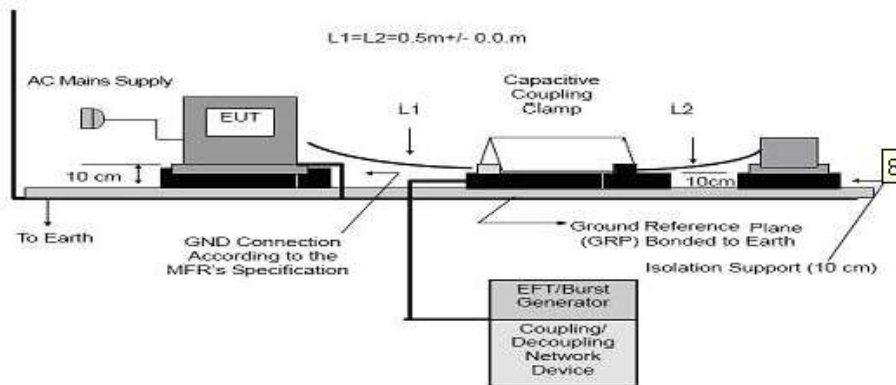
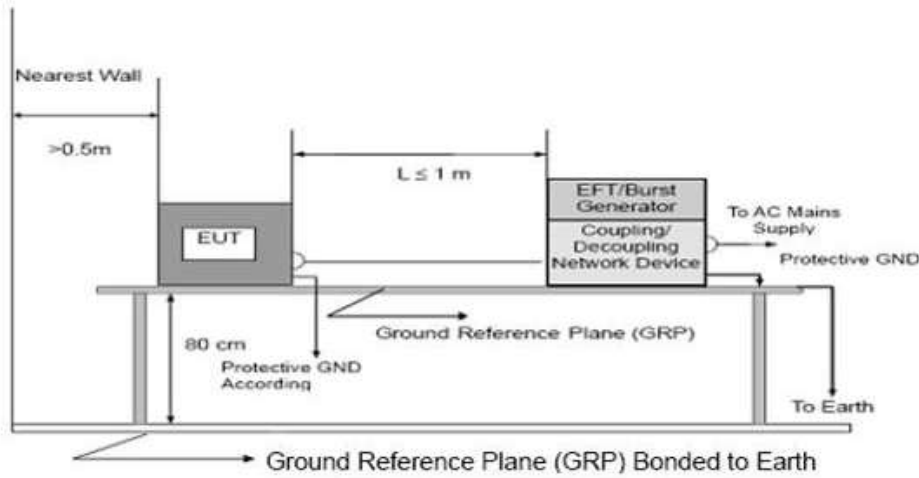

Note:

TABLE-TOP EQUIPMENT

The configuration consisted of a wooden table (0.8m high) standing on the Ground Reference Plane. The GRP consisted of a sheet of aluminum (at least 0.25mm thick and 2.5m square) connected to the protective grounding system. A minimum distance of 0.5m was provided between the EUT and the walls of the laboratory or any other metallic structure.

FLOOR-STANDING EQUIPMENT

The EUT installed in a representative system as described in section 7 of IEC/EN 61000-4-4 and its cables, were isolated from the Ground Reference Plane by an insulating support that is 0.1-meter thick. The GRP consisted of a sheet of aluminum (at least 0.25mm thick and 2.5m square) connected to the protective grounding system.

4.4.4 TEST RESULTS

N/A.

4.5 SURGE TESTING

4.5.1 TEST SPECIFICATION

Basic Standard:	IEC/EN 61000-4-5
Required Performance	B
Wave-Shape:	Combination Wave 1.2/50 us Open Circuit Voltage 8 /20 us Short Circuit Current
Test Voltage:	Power Line : 0.5 kV, 1 kV, 2 kV
Surge Input/Output:	L1-L2, L1-PE, L2-PE
Generator Source:	2 ohm between networks
Impedance:	12 ohm between network and ground
Polarity:	Positive/Negative
Phase Angle:	0 /90/180/270
Pulse Repetition Rate:	1 time / min. (maximum)
Number of Tests:	5 positive and 5 negative at selected points

4.5.2 TEST PROCEDURE

a. For EUT power supply:

The surge is to be applied to the EUT power supply terminals via the capacitive coupling network. Decoupling networks are required in order to avoid possible adverse effects on equipment not under test that may be powered by the same lines, and to provide sufficient decoupling impedance to the surge wave. The power cord between the EUT and the coupling/decoupling networks shall be 2meters in length (or shorter).

b. For test applied to unshielded unsymmetrically operated interconnection lines of EUT:

The surge is applied to the lines via the capacitive coupling. The coupling /decoupling networks shall not influence the specified functional conditions of the EUT. The interconnection line between the EUT and the coupling/decoupling networks shall be 2 meters in length (or shorter).

c. For test applied to unshielded symmetrically operated interconnection /telecommunication lines of EUT:

The surge is applied to the lines via gas arrestors coupling. Test levels below the ignition point of the coupling arrestor cannot be specified. The interconnection line between the EUT and the coupling/decoupling networks shall be 2 meters in length (or shorter).

d. For the actual test configuration, please refer to the related Item –EUT Test Photos.

4.5.3 TEST SETUP

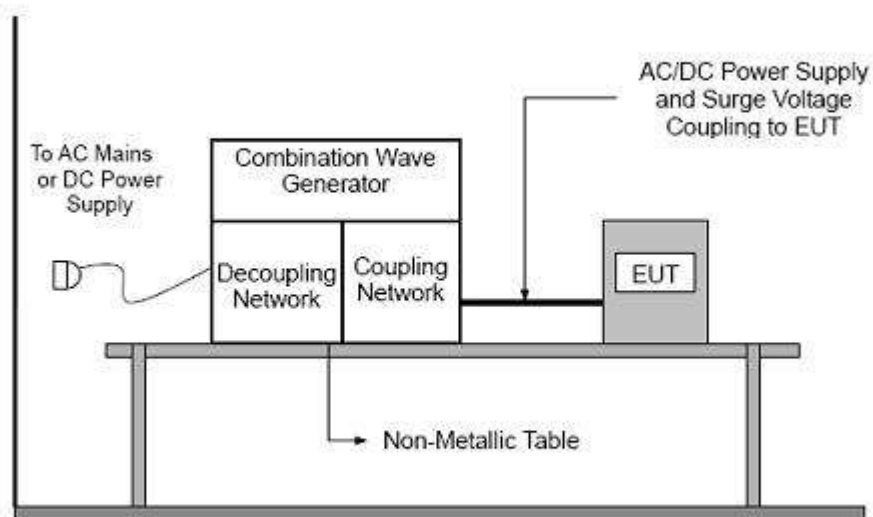

4.5.4 TEST RESULTS

N/A.

4.6 INJECTION CURRENT TESTING

4.6.1 TEST SPECIFICATION

Basic Standard:	IEC/EN 61000-4-6
Required Performance	A
Frequency Range:	0.15 MHz - 80 MHz
Field Strength:	3 Vr.m.s.
Modulation:	1kHz Sine Wave, 80%, AM Modulation
Frequency Step:	1 % of fundamental
Dwell Time:	at least 3 seconds

4.6.2 TEST PROCEDURE

The EUT and support equipment, are placed on a table that is 0.8 meter above a metal ground plane measured 1m*1m min. and 0.65mm thick min.

The other condition as following manner:

- a. The field strength level was 3V.
- b. The frequency range is swept from 150 KHz to 80 MHz, with the signal 80%amplitude modulated with a 1kHz sine wave. The rate of sweep did not exceed 1.5×10^{-3} decade/s. Where the frequency range is swept incrementally, the step size was 1% of fundamental.
- c. The dwell time at each frequency shall be not less than the time necessary for the EUT to be able to respond.
- d. For the actual test configuration, please refer to the related Item –EUT Test Photos.

4.6.3 TEST SETUP

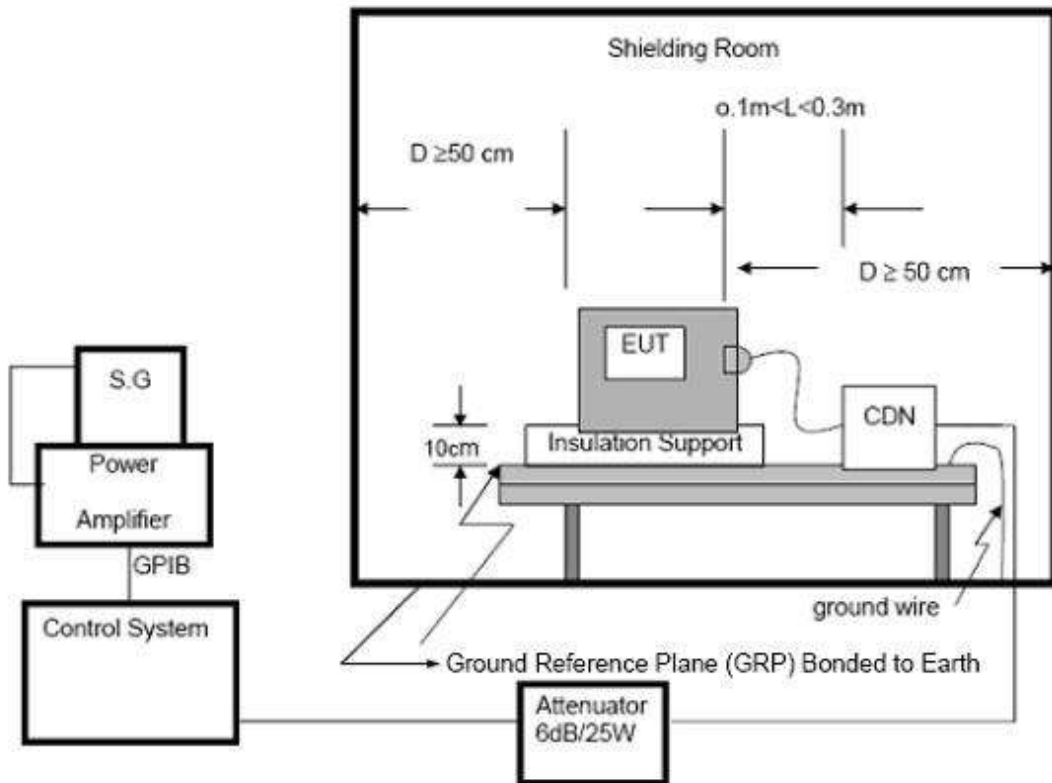

For the actual test configuration, please refer to the related Item –EUT Test Photos.

NOTE:

FLOOR-STANDING EQUIPMENT

The equipment to be tested is placed on an insulating support of 0.1 meters height above a ground reference plane. All relevant cables shall be provided with the appropriate coupling and decoupling devices at a distance between 0.1 meters and 0.3 meters from the projected geometry of the EUT on the ground reference plane.

4.6.4 TEST RESULTS

N/A.

4.7 VOLTAGE INTERRUPTION/DIPS TESTING

4.7.1 TEST SPECIFICATION

Basic Standard:	IEC/EN 61000-4-11
Required Performance	100% reduction, 0.5 Cycle 100% reduction, 1.0 Cycle 30% reduction, 25 Cycles
Voltage Interruptions:	100% reduction, 250 Cycles
Test Duration Time:	Minimum three test events in sequence
Interval between Event:	Minimum ten seconds
Phase Angle:	0°/45°/90°/135°/180°/225°/270°/315°/360°
Test Cycle:	3 times

4.7.2 TEST PROCEDURE

The EUT shall be tested for each selected combination of test levels and duration with a sequence of three dips/interruptions with intervals of 10 s minimum (between each test event). Each representative mode of operation shall be tested. Abrupt changes in supply voltage shall occur at zero crossings of the voltage waveform.

4.7.3 TEST SETUP

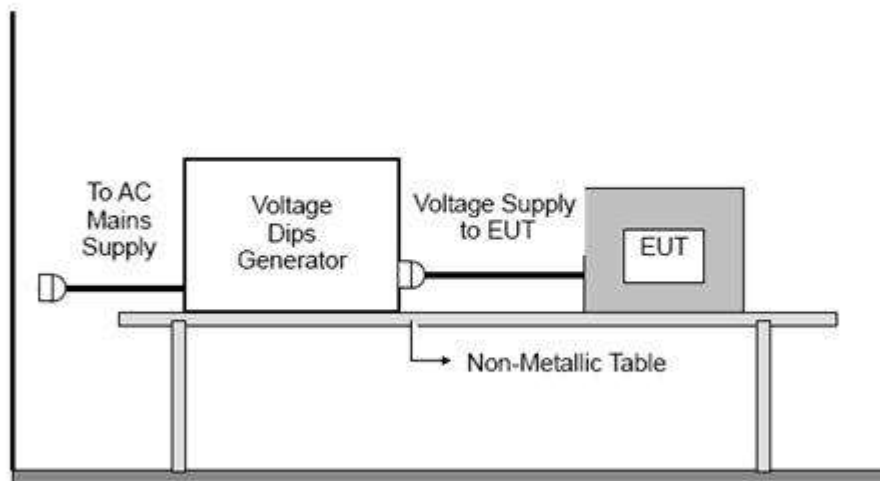

For the actual test configuration, please refer to the related Item –EUT Test Photos.

4.7.4 TEST RESULTS

N/A.

5. PHOTOS OF EUT





the end of report